rubber flooring artigo

Index

Introduction	4
Substrates	
a) Cement screeds	4
Radiant floor heating	5
b) Existing hard flooring	5
c) Special supports	5
Controls and requirements of substrates	
Levelling	6
Moisture	6
Cohesion	6
Cracks	6
Installation of rubber flooring	
Introduction	8
Smoothing underlayment	8
Receipt and storage of the flooring	8
Installation of rubber flooring	
Installation with adhesive	8
Conditions to be checked	8
Adhesives	9
Rolls	
Initial preparation for adhesive laying	10
Adhesive laying	12
Tiles	
Adhesive laying	14
Sealing of rubber flooring	
Heat sealing	16
Cold sealing	17
Installation of dissipative flooring (ANT48) (DIF in accordance with IEC 61340-4-1)	
General information	18
Adhesives	18
Grounding	18
Installation method	18
Testing	19
Site conditions	19
Installation of loose lay flooring (LL)	
Substrates	20
Installation	20
Notes	20
Installation of cement bonding flooring	
Substrates	22
Smoothing underlayment	22
Cement laying	22
Precautions	22
Cleaning and maintenance of Artigo rubber flooring	24

Introduction

The performance of Artigo rubber flooring depends on a number of factors such as the choice of the product, the preparation of subfloors, the installation and the correct maintenance.

This technical information manual is intended as a guide to all parties involved in the process in order to get the best possible results.

Our Technical Assistance is at your disposal for more analytic data and suggestions when choosing the floor.

The information in this handbook are valid when printed out.

We reserve the right to modify the quality standards without notice.

Substrates

The first pre-condition to get a good, durable and reliable installation of any resilient flooring is connected to the characteristics of the substrate which is prepared by the main contractor and must be checked by the specialised flooring layer before beginning the installation. This is why we hereby try to give a few basic principles about the substrate.

The most common substrates are:

- a) Cement screeds;
- b) Existing floors;
- c) Special substrates.

a) Cement screeds

The cement screed is the base supplied by the main contractor.

It should be supplied hard, solid, shock-resistant, free from cracks, with a minimum thickness of 4cm, dry and clean.

As far as the cement screed is concerned, we suggest the use of at least 350 kg/m³ of Portland 325 with proper aggregate, clean river sand and a water/cement ratio as low as possible considering the workability of the mix.

In case hydraulic and heating systems have to be incorporated, it is necessary to insulate the tubing, and to cast a cement screed with a minimum thickness of 6 cm, reinforced with a welded metal grid to avoid cracks and shrinkage.

Resilient floorings require the substrate to be dry either at the time of the installation and during their entire life. The maximum content of moisture allowed (by weight) is 2%.

This is why screeds which are direct to earth need to be properly ventilated and to have an effective damp proof membrane incorporated within them and continuous with the walls.

The surface of the screed must be solid and dense but not impervious cause in this case it will have to be ground or blasted to allow receiving the smoothing underlayment.

The mechanical resistance of the screed is of paramount importance since resilient flooring are not providing protection from concentrated loads.

Expansion joints are to be incorporated into buildings to allow movement without cracking and they have to be extended through the floor covering.

In general it is advised and economically irrelevant to lay a polyethylene sheet between the structural base and the screed to act as a damp proof membrane and to limit the water absorption of the base thus allowing a low water/cement ratio for the screed.

A few special instructions are to be followed in case of:

Radiant floor heating

The heating system has to be turned on before the installation of any floor covering to allow for conditioning of the screed. This is to make sure that after the first heating, the screed is not damaged by the sudden change of temperature or at least could be repaired before proceeding.

The operations to carry out are:

- 1) Do not turn the system on before 28 days from when the screed was cast.
- 2) The temperature of the heating fluid should be increased by 5 °C per day up to the maximum service temperature.
- 3) The maximum temperature has to be kept for at least three days.
- 4) Reduce temperature of 5°C a day to reach the same temperature of the room.
- 5) Heating must be turned off 24 hours before starting the smoothing underlayment.

The heating can be turned on gradually 24 hours after the installation of the floor.

b) Existing hard flooring

The most common floors in building renovations are ceramic, natural stone and cement. Loose tiles and grout should be removed and uneven areas filled up with adequate smoothing products.

In presence of waxes, it is necessary to wash with a solution of soda and hot water, rinse and apply a primer.

Grease, oil, paint should be removed by scarifying through mechanical action in order to remove them and facilitate the bonding of the smoothing underlayment.

c) Special supports

For special supports (metal decking, asphalt, timber etc.) please contact Artigo Technical Assistance.

Controls and requirements of substrates:

Whatever the substrate is made of, the flooring layer has to check it carefully and to ask the main contractor to undertake the actions required to correct the detected defects.

Levelling

Uneven surfaces or differences in level between areas will certainly require smoothing underlayment and or repair to be carried out;

Moisture

Residual moisture must be checked with a calcium carbide hygrometer and must be below 2% without suspects of future hydrostatic pressure;

Cohesion

After cleaning the substrate, the surface should not be easily scratchable with a metal point (such as a nail) and all contamination which could impair the effectiveness of the adhesive shall be removed;

Cracks

Any crack existing on the substrate shall be repaired before starting the smoothing underlayment. When cracks are going through the thickness, the screed has to be removed and cast once again.

In case the above mentioned basic requirements are not satisfied the installer should refuse to install.

Installation of rubber flooring: introduction

The specialised flooring layer in charge of installing the product, should choose the best procedure based on the actual conditions of the work area.

Smoothing underlayment

In order to reduce small local irregularities or excessive roughness of the base surface, it is sometimes necessary to apply a smoothing underlayment.

Before smoothing, the surface must be swept and/or vacuumed accurately.

Smoothing products can be supplied by several manufacturers as pre-mixed powders, which, when mixed with the appropriate liquefier, can be applied in a few mm thickness with a trowel in one or more layers.

24 hours after the smoothing, the surface should be ground to eliminate small residual roughness and cleaned using a vacuum cleaner.

Please always follow the manufacturer recommendations.

Receipt and storage of the flooring

A good installation starts with a proper storage of products:

- Check that the received material is correct in terms of quality, quantity and colour;
- In case of tiles, do not overlay more than two pallets or more than 150 tiles;
- rolls should be safely stored in an upright position;
- On arrival the material should be kept in the room where it will be installed at least 48 hours before laying (min. temperature 18°C).

Installation of rubber flooring

Installation with adhesive

The flooring suitable for adhesive bonding is ground on the back.

The adhesive bonding is the most common method to install rubber flooring, and it grants very good performances provided it is carried out correctly by skilled workers.

Conditions to be checked

- A working temperature between 18°C and 30°C is required for at least 24 hours prior to and during the installation, and for 24 hours afterwards;
- Relative humidity shall not exceed 75%;
- Substrate shall be suitable for the laying;
- Residual moisture in the substrate shall not exceed 2%.

Adhesives

Adhesives of different composition can be used according to the conditions and characteristics of the surfaces to be covered and strictly following the manufacturer's instruction:

Acrylic in water dispersion

The acrylic adhesives in water dispersion harden by evaporation and absorption of the water they contain, requiring therefore porous substrates.

They are suitable for indoor installations, on cement base surfaces, when light to medium traffic is expected and no large water quantities are used for the cleaning.

Two-components epoxy

Composed of an epoxy polymer (part A) which reticulates when mixed with a special hardener (part B). They harden through a chemical reaction between the two components.

Suitable for indoor use on cement base surfaces when medium or heavy traffic is expected.

Polyurethane two-components

Composed of a polyurethane polymer (part A) which reticulates when mixed with a special hardener (B).

They harden through a chemical reaction between the two components.

Suitable for indoor use on cement base surfaces when medium or heavy traffic is expected.

This kind of adhesive is also available in conductive version for the installation of dissipative flooring.

Polychloroprenic (contact adhesive)

Composed of Neoprene in dispersion with solvents that harden by evaporation and absorption through porous materials.

Suitable for the laying of accessories (skirtings, stair treads, etc.) thanks to the quick setting of this kind of adhesives (which have to be applied on both the surfaces to be bonded).

Use of adhesives

For a proper preparation and application of the adhesives, it is necessary to strictly follow the manufacturer's directions.

The adhesive must be applied with a notched trowel of the correct size notch which must be maintained during the application. The adhesive manufacturer provides details of the notch size to suit the adhesive and the application.

In case of low thickness flooring, the use of small notched trowel is advised to prevent the spreading marks to be visible once the adhesive has set.

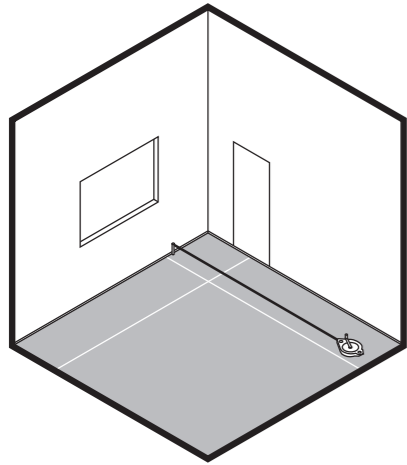

1.
Measure the room and mark the centrelines, planning the laying in a way to reduce cuts and scraps.

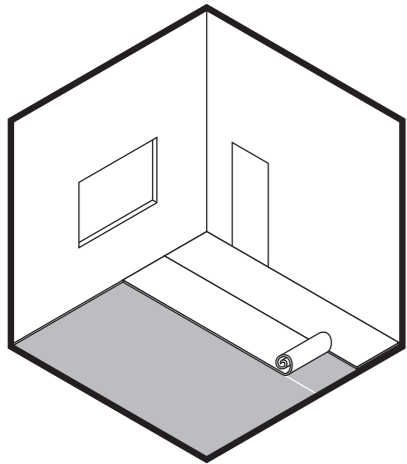

2.
Loose lay the rolls (without adhesive) following the marked lines. Rolls must be laid with 3,0 cm overlap along the adjoining edges. Check the uniformity of colour and the absence of defects.

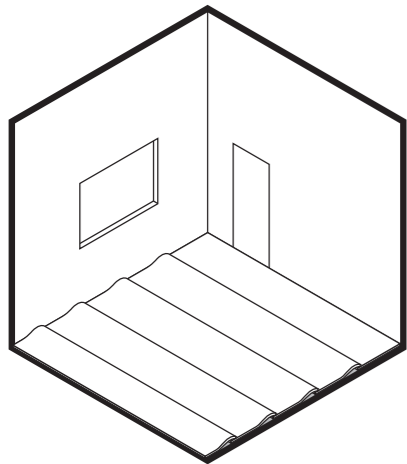
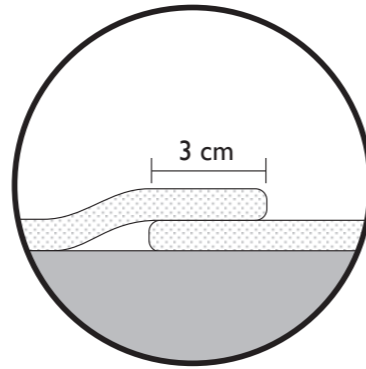

3.
The loose laying is very important to check the colour uniformity and the absence of defects of the flooring. All claims will be accepted only if the flooring is not yet permanently bonded.

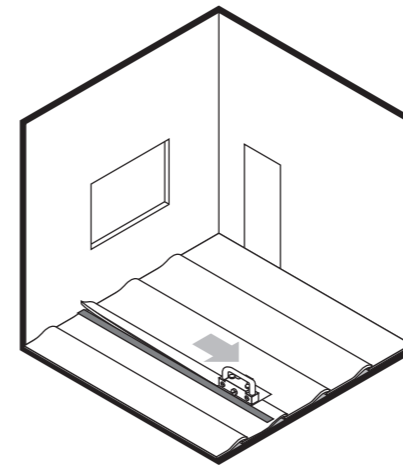

4.
Perform the seam cutting along the sides and the heads of the rolls (the use of scribes and straight and hook bladed knives is advised to get better results).

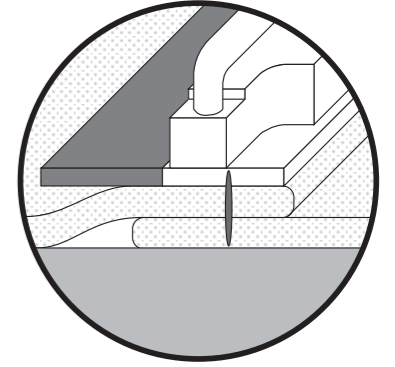

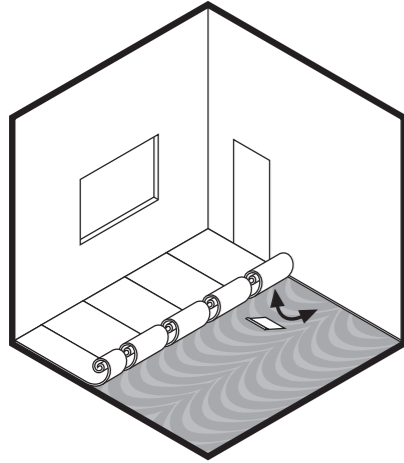

1.
Fold back the sheet to just over half its length. Spread the adhesive using a notched trowel. Once the adhesive is ready to accept the flooring, roll the sheet back into place, taking care not to twist the roll or to trap air bubbles, which will eventually have to be expelled through massaging.

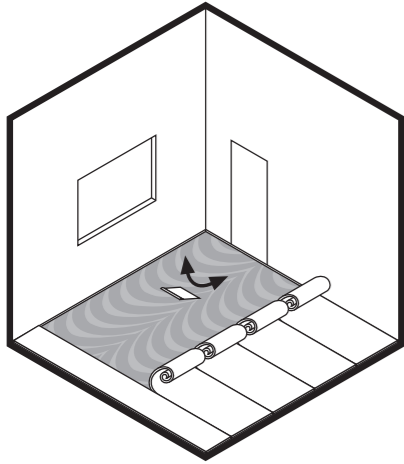

2.
Repeat the operation on the other half of the roll.

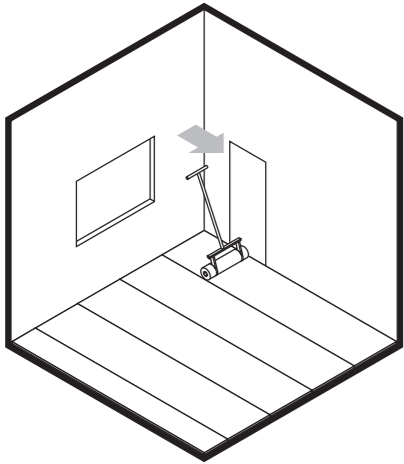

3.
After the laying, the use of a floor roller is recommended to ensure a perfect contact with the substrate.

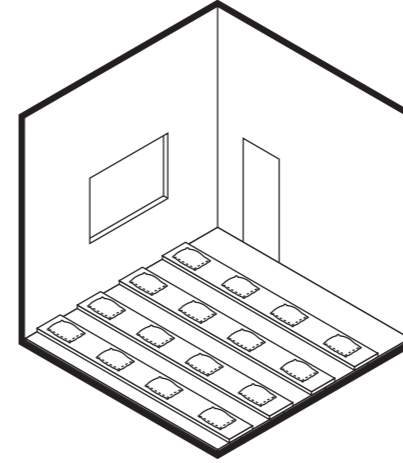

4.
In case adhesive with long tackifying time are used, apply weights along the joints (bricks, sand bags, etc.).

Notes

The excess adhesive shall be removed as work progresses and it is still wet, using a cloth with neutral detergent (in case of acrylic adhesive), or with alcohol for two component adhesives.

Avoid making concentrated pressure on the floor with hands elbows or knees, during the installation to prevent the formation of permanent indents; do not walk on the flooring for at least 24 hours after the installation.

When the laying is over a first cleaning will allow to check the result obtained.

Always protect the floor after the installation with protective sheeting to avoid unnecessary damage when installing further equipments.

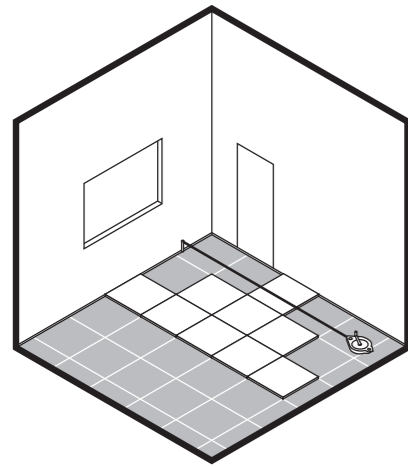

1.
Measure the room and mark the centrelines planning the laying in a way to reduce cuts and scraps.

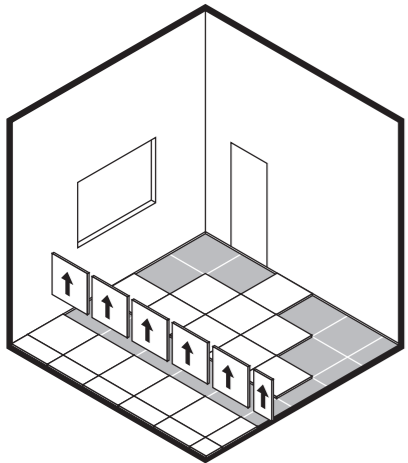

2.
Loose lay the tiles (without adhesive) starting along the centrelines and following the arrows printed on the back of the tiles taking special care to the alignment of joints and/or pattern.

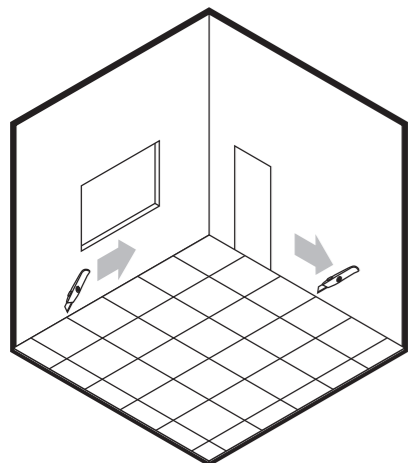

3.
Check the uniformity of colour and the absence of defects. The perimeter tiles will require to be trimmed off to be ready for bonding.

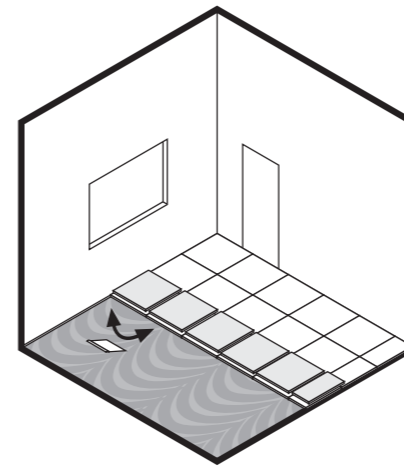

4.
Tip over a row of tiles at a time. Spread the adhesive with the proper notched trowel as advised by the manufacturer.

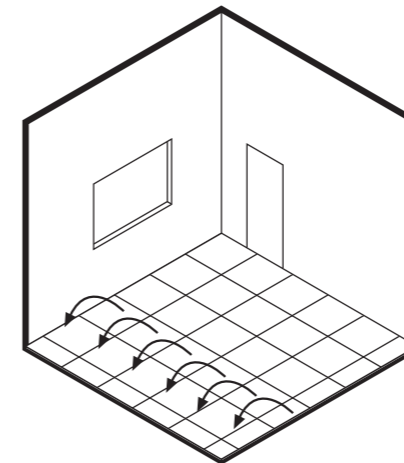

5.
Once the adhesive is ready to accept the tiles, put the tiles back in the starting position. Press/massage the flooring to make sure that all air is expelled and the tile is in full contact with the substrate.

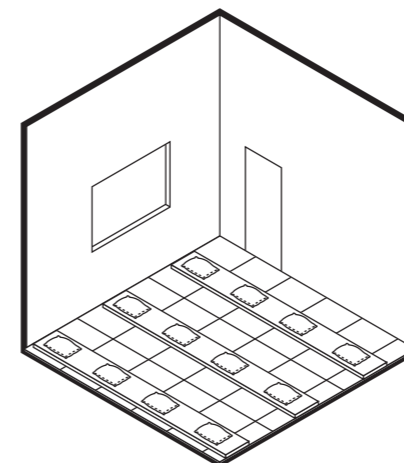

6.
Special care has to be taken with regards to the positioning of the tiles to make sure the alignment of joints and studs is accurate. In case adhesive with long tackifying time are used, apply weights along the joints (bricks, sand bags, etc.).

Sealing of rubber flooring

Thanks to their dimensional stability, Artigo rubber flooring do not need sealing. Nevertheless, they can be sealed (either hot or cold sealing can be performed) when it is required, in order to grant high standards of hygiene in applications such as hospitals, food or pharmaceutical industry where wet sterilisation could be performed. To prevent accumulation of dirt and bacteria into seams the self coving of the floor to the wall can be carried out by inserting a cove forming profile below the flooring.

Heat sealing

It is mandatory to use the Artigo sealing rod (diameter of about 3,8 mm) and to heat it through a sealing gun to melt it into the joint.

The guidelines provided below should be followed very carefully:

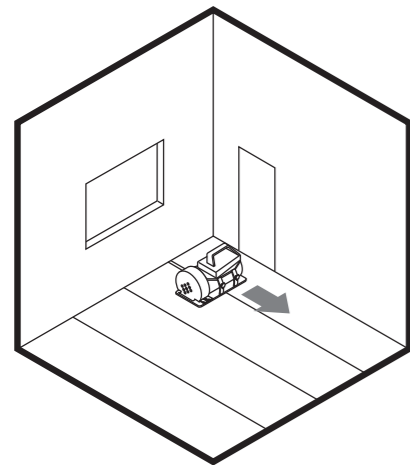

1. With a grooving tool (manual or powered), create a groove along the joints of tiles or rolls. The groove shall be cut to a depth of 2/3 of the flooring thickness (to a maximum of 2 mm) and a width of about 3.5 mm. Sweep accurately to remove any dust or trimmings from the groove. When laying Granito Elastic **the groove shall not affect the underlayer.**

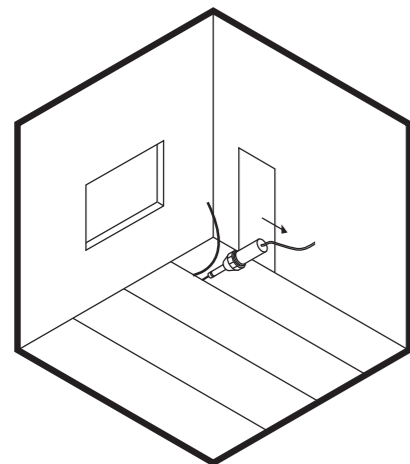
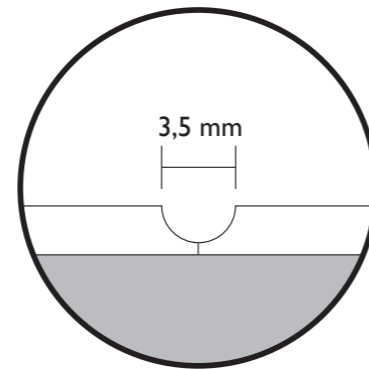

2. Place the sealing rod into the speedweld aperture, press the rod down into the groove and proceed at the right speed keeping the speedweld toe parallel to the rubber surface.

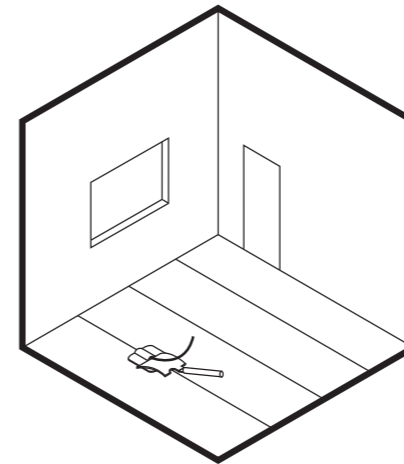
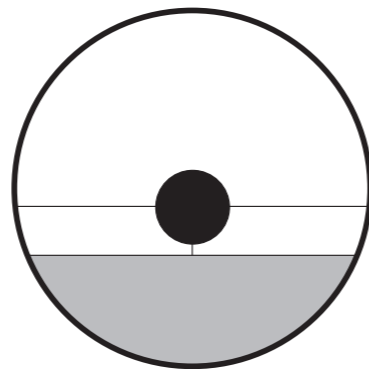

3. Using a sharp spatula knife placed on a trimming guide and trim off the first part of excess sealing rod. Heating the knife with the sealing gun may help the trimming.

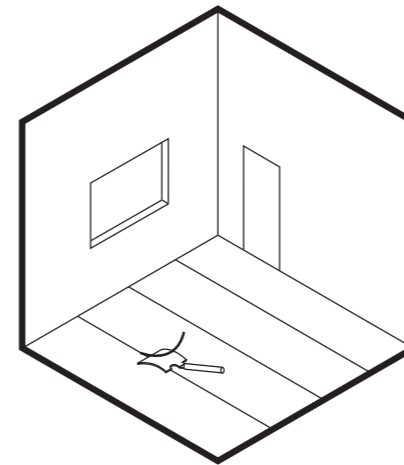
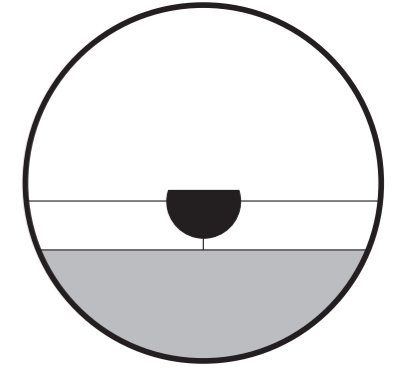

4. When the rod has cooled to room temperature the remaining excess should be trimmed using the spatula knife without the guide keeping a shallow angle between blade and floor to avoid "digging in". **Attention:** the colour of the rod cannot be exactly the same of the floor.

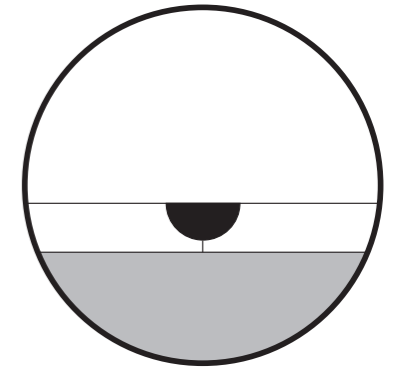

Cold sealing

In case studded flooring are used or when it is impractical to hot seal, it is possible to use a polymeric sealant to be spread in the joint through a suitable gun. Please ask Artigo Technical Assistance for details.

Installation of dissipative flooring (ANT48) (DIF in accordance with IEC 61340-4-1)

General information

Dissipative flooring are designed to specific resistance requirements for operating theatres, manufacture or assembly areas of electronic components or anywhere a protection from electrostatic charges is required (ESD).

This kind of products are identified in the Artigo range as ANT48 and comply with the most important international standards.

It is of paramount importance to make sure the specification of the product is fully understood and reference is made to the relevant standards.

For details about the substrate and smoothing underlayment, please refer to the previous points.

Adhesives

Sheets and tiles should be laid with conductive adhesive (Polyurethane two components is recommended).

In case Acrylic conductive adhesive is used, hot sealing of the joints is mandatory.

Copper foil strips are usually supplied by the manufacturers with adhesive backed tape or, in case they are not, polychloroprenic conductive adhesive could be used.

Grounding

Use of conductive adhesive is allowing equalisation of electrostatic potential for subsequent elimination via grounding system.

Copper foil strip (10 x 0.08 mm) should be laid in each room/area with a maximum grid size of 12 x 12 m either in case rolls or tiles are used. The copper strips should at least follow the perimeter of the room at a distance of about 20 cm from the walls. For large areas, lay extra strips at 12 m intervals running throughout the area.

One end of the foil strip must be brought out and connected in an earth connection box at least every 100 m² of area covered, to ensure a good drainage of the electrostatic charges.

We recommend utilising a qualified electrician to connect the copper strip to earth in compliance with local regulations.

Installation method

Once the substrate is ready to receive the flooring (swept and free from loose dust), draw the lines to be followed by the grid of copper strips and start installing by removing the protection to the adhesive backing, pressing the foil firmly in place and smoothing it with foot or cloth.

Spread the chosen conductive adhesive with a trowel as advised by the manufacturer.

Install the floor covering following the same techniques described in previous points for standard flooring.

Joints should be welded in applications requiring high standards of hygiene or where wet cleaning is employed frequently and acrylic adhesive has been used.

Protect the floor after installation with protective sheeting to avoid unnecessary damage when installing equipment and furniture.

Testing

Floors should be carefully swept and damp mopped after installation.

Testing should be carried out not less than 24 hours after laying and cleaning.

A test has to be carried out for each 5/10 m² of floor area and resistance measurements are to be tested to the earth point and also between adjacent sections.

Site conditions

A temperature between 18°C and 30°C is required during conditioning of the product and installation.

For Dissipative products it is particularly important to store the material on site and open the rolls at least 48 hours prior to final fitting.

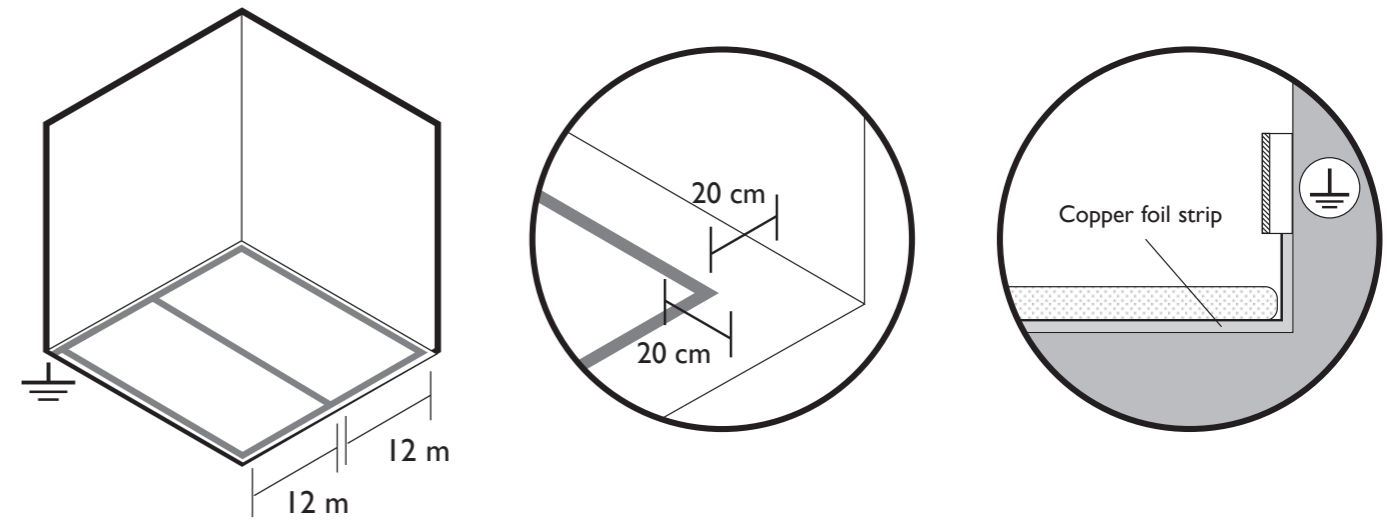

Installation of loose lay flooring (LL)

The Loose Lay rubber flooring is produced with a special technique which, giving the product added dimensional stability allows the installation without permanent adhesives. These family of products ("LL" in the Artigo range) can in fact be installed with adhesive in water dispersion performing a permanent tack thus avoiding skidding of the tiles whilst still allowing individual tiles to be removed and replaced if this is needed.

Substrates

These products can be installed on cement screeds, raised access panels or existing floors without any major difference in the installation method.

The subfloor must meet the same requirements as for the standard flooring with a slightly wider acceptance for residual moisture which could reach a maximum of 5 %.

In case of raised access floor, whatever the material constituting the panel is (wood, cement or other), the panel must be supplied with a surface suitable to receive loose lay products.

Installation

- The installation has to be carried out by qualified flooring layers.
- To ensure perfect stability, the tiles have to be acclimatised to the room in which the product will be installed for at least 48 hours before the installation.
- The temperature during the laying should be between 18 and 30°C.

Notes

In order to get the expected result it is very important to allow a proper drying time to the adhesive.

The quantity of adhesive to be used varies in accordance with the manufacturers directions but, in general, we advice to use the least possible.

In case of raised access floor, the joints of the rubber tiles should not be in coincidence with those of the panels.

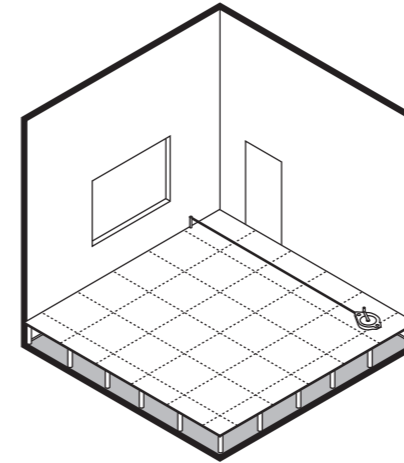

- 1.** Measure the room and mark the centrelines planning the laying in a way to reduce cuts and scraps.

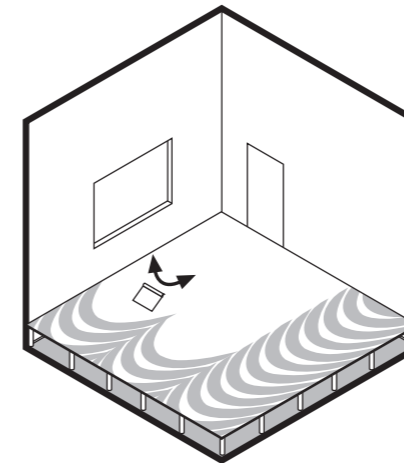

- 2.** Apply the permanent tackifier with a notched trowel in accordance with the instruction of the manufacturer. Allow the adhesive to dry sufficiently.

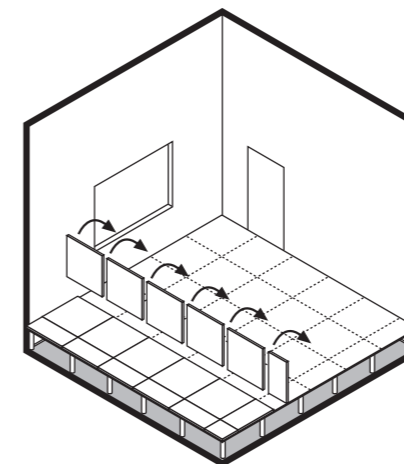

- 3.** Lay the tiles starting along the centrelines and following the arrows printed on the back of the tiles taking special care to the alignment of joints. Cut the perimeter tiles to fit.

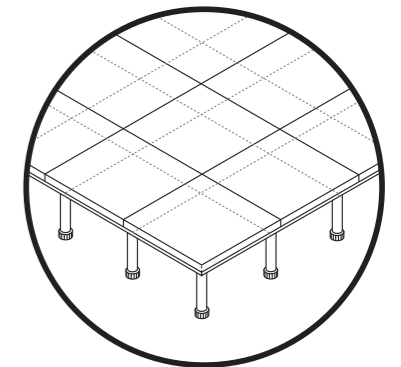

Installation of cement bonding flooring

The use of cement bonding flooring is advised when the substrate is affected by residual moisture or subject to very heavy traffic and in particular:

- Screeds direct to earth;
- Underground street crossings or similar;
- Outdoor walkways;
- Garages.

The cement bonding floor, thanks to its dove-tail backing creates, in fact, a mechanical bonding to the subfloor.

Substrates

The usual subfloor for this products is a slab of concrete properly reinforced with metal grids.

As far as the cement screed is concerned, we suggest the use of at least 350 kg/m³ of Portland 325 with proper aggregate, clean river sand and a water/cement ratio as low as possible allowing the workability of the mix.

The laying operations should start within 15 days after the concrete has been cast, when the curing is not yet completed.

On pre-existing screeds, it is necessary to clean the surface and wash abundantly avoiding water stagnation before starting with the laying.

Smoothing underlayment

If the support is not sufficiently smooth it will be necessary to level it with a mixture of cement type 325 and fine sand (2:1 ratio), to be spread with a metal trowel.

Cement laying

The laying of rubber flooring should be carried out by skilled staff only.

When a quick drying of the cement is requested, it is possible to replace the compound cement/sand with quick-setting cement adhesives (drying times of about 24 hours).

Precautions

After laying each row of tiles it is necessary to clean the surface with a sponge to remove the exceeding mortar; when carrying out this operation, excess water is to be avoided on the surface of the tiles.

During laying operations, the flooring should be protected from sun rays, since strong thermal expansions could break the mechanical bondage of the cement when not yet completed. Damp sawdust left on the surface of the tiles could help to protect them from sun exposure.

After 48 hours from laying, clean the flooring with a vertical bristle mechanical monobrush and sawdust.

The flooring can be walked over (light traffic) only after 4 days and 10 days at least must be allowed for heavy traffic.

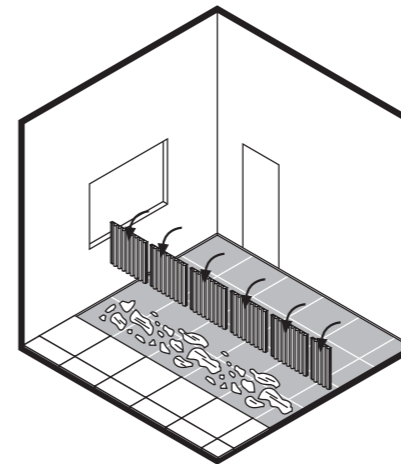

- 1.** Moisten well the surface to be covered. Loose lay the tiles, making sure joints and studs are correctly aligned; check the uniformity of the colour and the absence of defects.

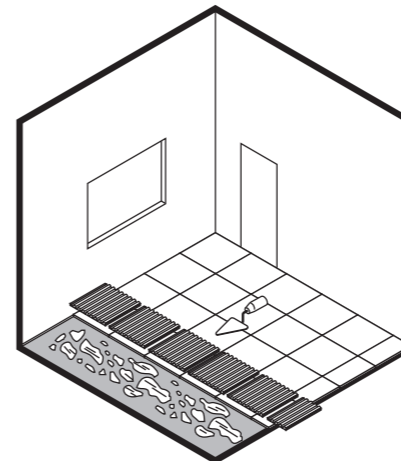

- 2.** Tip over the first row of tiles. Fill properly the dove-tail backing of the tiles with a mixture of 325 cement, sand (ratio 2:1) and water to obtain a suitable density.

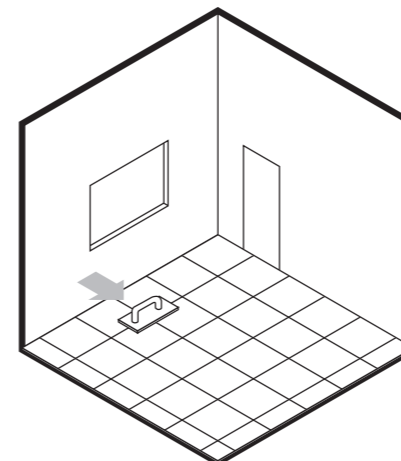
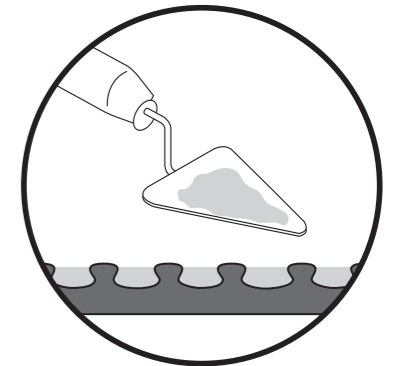

- 3.** Prepare a liquid mortar of cement 325 and water and spread it on the screed. Lay the tiles back in the starting position and fit them with a trowel. Press/massage the tiles to make sure that all air is expelled and the tile is in full contact with the substrate; let the exceeding mortar come out from joints.

Cleaning and maintenance of rubber flooring Artigo PRO

Artigo PRO innovative treatment gives to the rubber floor a reinforcement to the surface which enhances its hardness and wear resistance. The polymeric coating PRO, reticulated UV, ensures an easier initial cleaning, as well as the daily and ordinary maintenance, because it does not require the traditional coat of polish.

An effective passive dirt-barrier system, like matting and grids, is required to reduce the amount of dirt, grit and moisture in the areas where the flooring is installed.

After the laying is completed, protective sheets are to be laid on the floor covering to avoid unnecessary damage by heavy equipment, furniture, or any other work that will be completed after the floor installation.

Always fit protective soft feet to furnitures, tables and chair legs to prevent scratching. Protective feet must have suitable size in order to spread the load on a larger surface.

First cleaning after the installation

- Remove all loose debris, dust and any residual sand with broom or vacuum.
- Clean the floor covering with a neutral detergent using a mop or a combined machine in larger areas.
- In case of heavy dirt, it is recommended to clean the flooring using a low speed monobrush equipped with light abrasive disc (red disc in the 3M scale) and neutral detergent or lightly alkaline depending on dirt. Wet vacuum, rinse and leave to dry.
- If a glossy finish is required, a spray-buffing cleaning system can be used with high-speed rotary machine equipped with appropriate disc. For the description of these operations please make reference to Artigo Spa.

Daily maintenance

- Remove dust, dirt and stains from the floor.
- Clean with broom and damp yarn, micro-fibre mops or vacuum. Combined machine with neutral detergents is suggested in larger areas.
- Remove dirt marks and stains with a neutral or lightly alkaline detergent (diluted as per manufacturer's instructions).

Routine maintenance

Complete the daily cleaning washing the floor with water and neutral detergent.

- Clean the floor covering with a neutral detergent using a mop or a combined machine for larger areas.
- As alternative, it is also possible to carry out a periodic dry cleaning-and-maintenance system (spray cleaning/spray buffing) using rotary machines equipped with appropriate discs. The speed of the machine and the type of detergent/floor maintainer is to be selected depending on the level of dirt and on the desired level of gloss. For the description of these operations please make reference to Artigo Spa.

Periodic maintenance

- When standard maintenance operations are not sufficient to remove dirt, it is recommended a deeper cleaning in order to restore the initial appearance of the flooring.
- Clean the flooring with a neutral detergent (or lightly alkaline depending on dirt) using a low speed monobrush equipped with red disc. Wet vacuum, rinse and leave to dry.
- If necessary, restore the desired level of gloss using a spray-buffing system. Also in this case, the speed of the machine and the type of detergent/floor maintainer is to be selected depending on the level of dirt and on the desired level of gloss. For the description of these operations please make reference to Artigo Spa.

Warning

- In most instances, the above maintenance regime will be sufficient to ensure the floor covering to retain the best appearance. However where very heavy traffic is expected, a metallised emulsion should be applied: after the first cleaning, with perfectly clean and dry floor, a film of polish (with the desired grade of gloss) can be applied using an applicator. Apply a first coat of pure polish thinly and evenly across the floor and let then dry for about 30/40 minutes; when first coat is dry, a second coat should be applied at right angles to the direction of the first. After the complete drying of the layer (usually 2 hours), the floor is ready to be used.
- All products for cleaning and maintenance must be used in strictly accordance with the manufacturer's instructions.
- Do not use concentrated degreaser/stripper on PRO treated flooring: if required, use a lightly alkaline detergent.
- All kind of cleaning processes shall not be carried out under direct sunlight in order to avoid that dirty liquid dries before being removed, thus causing spots and stains on the flooring.
- Avoid to use very abrasive discs with the monobrush (blue, green, brown, black). The blue/green disc can be used only to remove the old layers of polish if this was applied.
- Chairs and/or furniture castor wheels must be soft, type W according to the EN 12529.

Notes

- These instructions are valid only for ARTIGO PRO flooring. For all other types please make reference to the specific Technical Documents.

Cleaning and maintenance of rubber flooring Artigo TXL

The superficial treatment of post vulcanization TXL gives to the rubber floor's surface a much lower porosity than in the traditional rubber floors, thus enhancing their resistance to soiling and ease their cleanability.

In areas subject to light traffic and regularly cleaned with monobrush, the TXL treatment makes no longer necessary the traditional coat of polish.

An effective passive dirt-barrier system, like matting and grids, is required to reduce the amount of dirt, grit and moisture in the areas where the flooring is installed.

After the laying is completed, protective sheets are to be laid on the floor covering to avoid unnecessary damage by heavy equipment, furniture, or any other work that will be completed after the floor installation.

Always fit protective soft feet to furnitures, tables and chair legs to prevent scratching. Protective feet must have suitable size in order to spread the load on a larger surface.

First cleaning after the installation

- Remove all loose debris, dust and any residual sand with broom or vacuum.

1ST case - for those areas with low traffic and that will be regularly cleaned with monobrush:

- Clean the flooring using a low speed monobrush equipped with light abrasive disc (red disc in the 3M scale) and neutral detergent or lightly alkaline depending on dirt. Wet vacuum, rinse and leave to dry.
- If a glossy finish is required, a spray-buffing cleaning system can be used with high-speed rotary machine equipped with appropriate disc. For the description of these operations please make reference to Artigo Spa.

2ND case - for all other situations:

- Wash the floor covering with an alkaline detergent using a low speed monobrush equipped with red disc in the 3M scale. Wet vacuum and rinse several times to remove any residual of detergent, leave to dry.
- With perfectly clean and dry floor, a film of polish (with the desired grade of gloss) can be applied. Using an applicator, apply a first coat of pure polish thinly and evenly across the floor and let then dry for about 30/40 minutes; when first coat is dry, a second coat should be applied at right angles to the direction of the first. After the complete drying of the layer (usually 2 hours), the floor is ready to be used.

Daily maintenance

- Remove dust, dirt and stains from the floor.
- Clean with broom and damp yarn, micro-fibre mops or vacuum. Combined machine with neutral detergents is suggested in larger areas.
- Remove dirt marks and stains with a neutral or lightly alkaline detergent (diluted as per manufacturer' instructions).

Routine maintenance

Complete the daily cleaning washing the floor with water and neutral detergent.

- Clean the floor covering with a neutral detergent using a mop or a combined machine for larger areas.
- As alternative, it is also possible to carry out a periodic dry cleaning-and-maintenance system (spray cleaning/spray buffing) using rotary machines equipped with appropriate discs. The speed of the machine and the type of detergent/floor maintainer is to be selected depending on the level of dirt and on the desired level of gloss. For the description of these operations please make reference to Artigo Spa.

Periodic maintenance

- When standard maintenance operations are not sufficient to remove dirt, it is recommended a deeper cleaning in order to restore the initial appearance of the flooring.
- Clean the flooring with a neutral detergent (or lightly alkaline depending on dirt) using a low speed monobrush equipped with red disc. Wet vacuum, rinse and leave to dry.
- If the flooring had been previously polished, it is recommended also to use a "wash and wax" product with the mop; this type of product is able to clean and maintain the floor in one step, leaving a thin layer of polish that enhances the aspect and durability of the original layer of polish.
- If necessary, restore the desired level of gloss using a spray-buffing system. Also in this case, the speed of the machine and the type of detergent/floor maintainer is to be selected depending on the level of dirt and on the desired level of gloss. For the description of these operations please make reference to Artigo Spa.

Restoring maintenance

To be carried out when a film of polish has been applied and if it has been damaged and can not be maintained any longer with the above maintenance processes.

- Wash the floor covering with a solution of a degreasing detergent (stripper) diluted in hot water using a low speed monobrush equipped with green disc in the 3M scale. Wet vacuum and rinse several times to remove any residual of detergent, leave to dry.
- With perfectly clean and dry floor, a film of polish (with the desired grade of gloss) can be applied. Using an applicator, apply a first coat of pure polish thinly and evenly across the floor and let then dry for about 30/40 minutes; when first coat is dry, a second coat should be applied at right angles to the direction of the first. After the complete drying of the layer (usually 2 hours), the floor is ready to be used.

Warning

- All products for cleaning and maintenance must be used in strictly accordance with the manufacturer's instructions.
- All kind of cleaning processes shall not be carried out under direct sunlight in order to avoid that dirty liquid dries before being removed, thus causing spots and stains on the flooring.
- Avoid to use very abrasive discs with the monobrush (blue, green, brown, black). The blue/green disc can be used only to remove the old layers of polish if this was applied.
- Chairs and/or furniture castor wheels must be soft, type W according to the EN 12529.

Notes

- A correct and complete maintenance program will allow the Client to limit the Restoring activities with degreasing agents and new polish.
- These instructions are valid only for ARTIGO TXL flooring. For all other types please make reference to the specific Technical Documents.

Cleaning and maintenance of rubber flooring Artigo Standard

An effective passive dirt-barrier system, like matting and grids, is required to reduce the amount of dirt, grit and moisture in the areas where the flooring is installed.

After the laying is completed, protective sheets are to be laid on the floor covering to avoid unnecessary damage by heavy equipment, furniture, or any other work that will be completed after the floor installation.

Always fit protective soft feet to furnitures, tables and chair legs to prevent scratching. Protective feet must have suitable size in order to spread the load on a larger surface.

First cleaning after the installation

- Remove all loose debris, dust and any residual sand with broom or vacuum.
- Wash the floor covering with an alkaline detergent using a low speed monobrush equipped with red disc in the 3M scale. Wet vacuum and rinse several times to remove any residual of detergent, leave to dry.
- With perfectly clean and dry floor, a film of polish (with the desired grade of gloss) can be applied. Using an applicator, apply a first coat of pure polish thinly and evenly across the floor and let then dry for about 30/40 minutes; when first coat is dry, a second coat should be applied at right angles to the direction of the first. After the complete drying of the layer (usually 2 hours), the floor is ready to be used.

Daily maintenance

- Remove dust, dirt and stains from the floor.
- Clean with broom and damp yarn, micro-fibre mops or vacuum. Combined machine with neutral detergents is suggested in larger areas.
- Remove dirt marks and stains with a neutral or lightly alkaline detergent (diluted as per manufacturer' instructions).

Routine maintenance

Complete the daily cleaning washing the floor with water and neutral detergent.

- Clean the floor covering with a neutral detergent using a mop or a combined machine for larger areas.
- As alternative, it is also possible to carry out a periodic dry cleaning-and-maintenance system (spray cleaning/spray buffing) using rotary machines equipped with appropriate discs. The speed of the machine and the type of detergent/floor maintainer is to be selected depending on the level of dirt and on the desired level of gloss. For the description of these operations please make reference to Artigo Spa.

Periodic maintenance

When standard maintenance operations are not sufficient to remove dirt, it is recommended a deeper cleaning in order to restore the initial appearance of the flooring.

- Clean the flooring with a neutral detergent (or lightly alkaline depending on dirt) using a low speed monobrush equipped with red disc. Wet vacuum, rinse and leave to dry.
- It is recommended also to use a "wash and wax" product with the mop; this type of product is able to clean and maintain the floor in one step, leaving a thin layer of polish that enhances the aspect and durability of the original layer of polish.
- If necessary, restore the desired level of gloss using a spray-buffing system. Also in this case, the speed of the machine and the type of detergent/floor maintainer is to be selected depending on the level of dirt and on the desired level of gloss. For the description of these operations please make reference to Artigo Spa.

Restoring maintenance

To be carried out when the protective film layer is damaged and can not be maintained any longer with the above maintenance processes.

- Wash the floor covering with a solution of a degreasing detergent (stripper) diluted in hot water using a low speed monobrush equipped with green disc in the 3M scale. Wet vacuum and rinse several times to remove any residual of detergent, leave to dry.
- With perfectly clean and dry floor, a film of polish (with the desired grade of gloss) can be applied. Using an applicator, apply a first coat of pure polish thinly and evenly across the floor and let then dry for about 30/40 minutes; when first coat is dry, a second coat should be applied at right angles to the direction of the first. After the complete drying of the layer (usually 2 hours), the floor is ready to be used.

Warning

- All products for cleaning and maintenance must be used in strictly accordance with the manufacturer's instructions.
- All kind of cleaning processes shall not be carried out under direct sunlight in order to avoid that dirty liquid dries before being removed, thus causing spots and stains on the flooring.
- Avoid to use very abrasive discs with the monobrush (blue, green, brown, black). The blue/green disc can be used only to remove the old layers of polish as described above.
- Chairs and/or furniture castor wheels must be soft, type W according to the EN 12529.

Notes

- A correct and complete maintenance program will allow the Client to limit the Restoring activities with degreasing agents and new polish.
- These instructions are valid only for ARTIGO "STANDARD" flooring. For all other types please make reference to the specific Technical Documents.

Maintenance troubleshooting**Colour variation**

- Due to cleaning equipments contaminated by chlorine water or similar: Ground clean the flooring or replace the floor covering.

Darkening or yellowing of the flooring

- Due to the build up of dirty wax: Check the correct use of the floor maintainer and re-start the maintenance process with a strip off.

Massive presence of scratches on the flooring

- Insufficient passive dirt barrier system: improve and/or increase the dirt barrier.

Greasy staining on the polish layer

- The ground cleaning has been partially ineffective: re-start the maintenance after stripping off.

White stains on the polish layer

- The protection layer has come in contact with alcoholic agents: re-start the maintenance after stripping off.

3M pads scale

White	Soft, for daily maintenance
Yellow	Soft, for burnishing and periodic maintenance
Blue	Medium, for stronger periodic maintenance
Red	Medium, for ground cleaning
Yellow/Green	Medium/strong, for ground cleaning and to strip off old layers of polish
Green	Strong
Brown	Abrasive
Black	Strongly abrasive